



Version 14 : September 2020

Mill/Turn



Proprietary Notice

This document contains proprietary information of Cambrio Acquisition, LLC (“CAMBRIO”) and is to be used only pursuant to and in conjunction with the license granted to the licensee with respect to the accompanying licensed software from CAMBRIO. Except as expressly permitted in the license, no part of this document may be reproduced, transmitted, transcribed, stored in a retrieval system, or translated into any language or computer language, in any form or by any means, electronic, magnetic, optical, chemical, manual or otherwise, without the prior expressed written permission from CAMBRIO or a duly authorized representative thereof.

It is strongly advised that users carefully review the license in order to understand the rights and obligations related to this licensed software and the accompanying documentation.

Use of the computer software and the user documentation has been provided pursuant to a CAMBRIO licensing agreement.

Copyright © 2021 CAMBRIO. All rights reserved. The Gibbs and GibbsCAM logos, GibbsCAM, Gibbs, Virtual Gibbs, and “Powerfully Simple. Simply Powerful.” are either trademark(s) or registered trademark(s) of CAMBRIO in the United States and/or other countries. All other trademark(s) belong to their respective owners.

Portions of this software and related documentation are copyrighted by and are the property of Siemens Digital Industries Software.

Microsoft, Windows, and the Windows logo are trademarks, or registered trademarks of Microsoft Corporation in the United States and/or other countries.

Contains PTC Creo GRANITE® Interoperability Kernel by PTC Inc. All PTC logos are used under license from PTC Inc., Boston, MA, USA. CAMBRIO is an Independent Software Provider.

Portions of this software © 1994-2021 Dassault Systèmes / Spatial Corp.

Portions of this software © 2001-2021 Geometric Software Solutions Co. Ltd.

Contains Autodesk® RealDWG™ kernel by Autodesk, Inc., © 1998-2021 Autodesk, Inc. All rights reserved.

DMG MORI Models provided in conjunction with GibbsCAM © 2007-2021 DMG Mori Seiki Co., Ltd.

Contains VoluMill™ and VoluTurn™ software by Celeritive Technologies, Inc. © 2007-2021 Celeritive Technologies, Inc. All rights reserved.

This Product includes software developed by the OpenSSL Project for use in the OpenSSL Toolkit (<http://www.openssl.org/>). This Product includes cryptographic software written by Eric Young (eay@cryptsoft.com).

Portions of this software © MachineWorks Ltd.

Portions of this software and related documentation are copyrighted by and are the property of Electronic Data Systems Corporation.

Other portions of GibbsCAM are licensed from GibbsCAM licensors, which may not be listed here.

Contents

MILL/TURN	5
Interface	5
Machining Palette	5
Coordinate Systems	6
What is a Coordinate System?	6
HVD vs. XYZ	7
CS Grid and Axis Marker	7
Graphics Preference	8
CS List	8
CS Frame Indicator	9
Menu Items	9
Edit Menu	9
View Menu	10
Modify Menu	11
Terminology	11
Comparison Summary	11
PART SETUP	13
Machine Definition Documents	13
Radius/Diameter	13
Mill/Turn Coordinate Systems	13
OPERATIONS AND COORDINATE SYSTEMS	14
Turning Operations	14
Milling Operations	14
Approach Types and CS Use in Mill/Turn	14
Standard Turning CS	14
Standard OD Milling CS	15
Standard Front Face Milling CS	15
Standard Back Face Milling CS	16

Geometry Creation	16
Tool Orientation	17
Tool Orientation Diagram	18
TOOL SETUP DATA	19
MACHINING	20
Processes	20
Milling Rotate Tab	20
Y Axis Interpolation and C Axis Interpolation	21
MILL/TURN WITH POLAR & CYLINDRICAL MILLING	23
C Axis Interpolation for Polar and Cylindrical Milling	23
Rotate Tab	23
Radial Geometry	23
Defining a Rotary WG	23
CONVENTIONS	25
Text	25
Graphics	25
LINKS TO ONLINE RESOURCES	26

Mill/Turn

Mill/Turn capabilities are available when both the Mill and Turning modules of the software are accessible. Mill/Turn allows you to create milling and turning operations within the same part. All milling and turning functions are available for Mill/Turn parts. Additional modules are available that increase the capabilities of Mill/Turn, most importantly the Polar & Cylindrical Milling option, which provides the ability to wrap any shape or toolpath around the C axis using rotary axis interpolation.

The Mill/Turn functionality of the software provides capabilities for programming single-spindle, single-turret turning machines that have the capability of driving live tooling. The turret positions can drive live tools such as endmills and drills that can be oriented along the Z axis, toward the chuck (face machining), or along the X axis, toward the turret (OD machining). In order to perform milling operations, the spindle must be changed from its normal function of spinning the part into a third programmable axis, usually designated as the C axis. The Mill/Turn functionality allows users to position the part by specifying angular rotations of the C axis.



Note: This symbol on the right signifies Mill/Turn functions that are enhanced by the Advanced CS module.



Interface

In order to use the Mill/Turn functions the Level 2 interface must be activated from the **File > Preferences > Interface** dialog.

Machining Palette

When a Mill/Turn MDD is selected, the Machining palette contains both Mill and Turning processes.

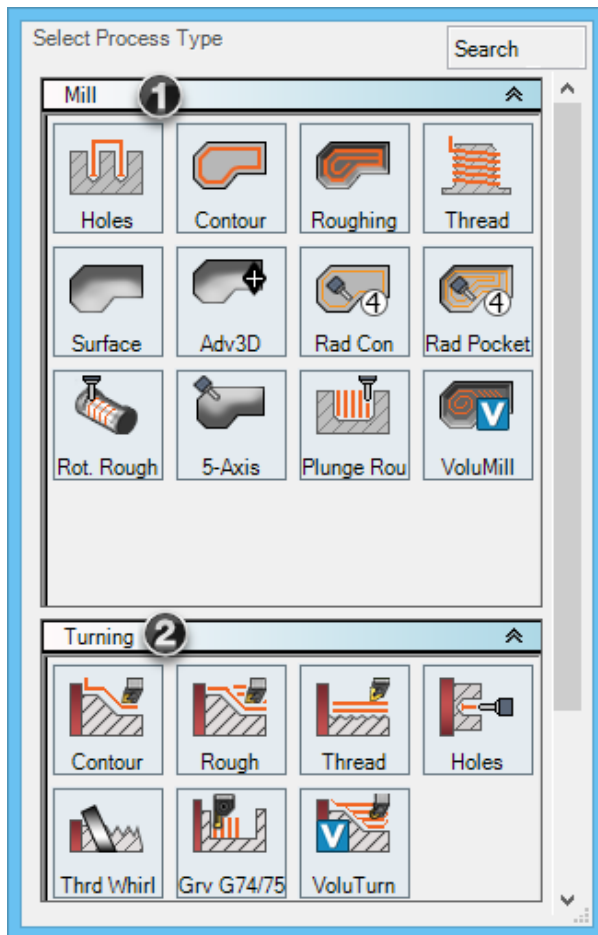

1. Mill processes
2. Turning processes

The Process List can hold a mixture of Mill and Turning processes.

Coordinate Systems

If you have the Advanced CS option, it is recommended that you cover the material in the [Advanced CS](#) guide. The following is the limited interface information on coordinate systems, and is intended as information for users who do not have the Advanced CS option installed.

What is a Coordinate System?

- A Coordinate System is a plane in space with an origin and three axes.

The origin is the point at which the axes intersect and serves as a zero reference point. The three axes are the horizontal, vertical and depth axes. In the standard lathe ZX plane, the Z is horizontal, the X is vertical, and the Y is the depth.

- A Coordinate System is NOT a Workgroup.

Coordinate systems are independent of workgroups. Multiple coordinate systems can be used in one workgroup and the same coordinate system can be used in multiple workgroups.

- A coordinate system is an attribute of geometry elements (points, lines, circles, etc.).

Geometry can be defined with a CS as the foundation but it is not dependent upon it. Geometry can remain while its CS foundation can be deleted (User CS via Advanced CS). However the geometry must be changed to use another CS as the foundation for its attributes.

HVD vs. XYZ

These letters are reference labels for the axes of a coordinate system. Every coordinate system must have an H, V and D Axis. X, Y and Z are the labels used for the horizontal, vertical and depth axes of the standard XY plane. The labels X, Y and Z will be used as the axis labels if any or all of the axes align with the standard XY plane. The labels used in the dialog may vary when the current coordinate system aligns with one of the primary planes. The labels X, Y and Z will be used instead of H, V and D. These text boxes may be labeled X, Y or Z if the current coordinate system aligns with one of the primary planes. Dialog boxes use the appropriate letters. Regardless, the values always appear in the same order in the dialog boxes, horizontal, vertical and then depth.

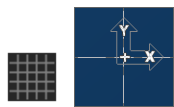

CS Grid and Axis Marker

The coordinate system (CS) grid and Axis markers are very important tools when working with multiple coordinate systems. The CS grid graphically displays the planar orientation of the current coordinate system. The CS grid and Axis markers will be drawn on the screen when the CS Grid button in the Floating Toolbar is selected. When creating multiple coordinate systems, the CS grid should be displayed on the screen at all times.

The CS Axis markers will be placed at the origin of the current coordinate system. The Axis marker arrows show the positive direction of the horizontal (H) and vertical (V) axes.

At the intersection of the Axis marker arrows, there is either a plus “+” or minus “-” sign. This indicates the polarity (positive/negative direction) of the Depth (D) Axis with respect to the current view.

When the horizontal and vertical axes align with one of the primary axes, the system labels the Axis markers with X, Y and Z. This is the case with three of the four coordinate systems used with Mill/Turn parts, the ZX plane, the XY plane and the YZ plane. The other CS is labeled with HY because the X Axis is flipped in the opposite direction.

The grid is drawn in dark gray and shows the plane of the current coordinate system. Additional light gray lines will be drawn showing where the coordinate system intersects with the workspace stock.

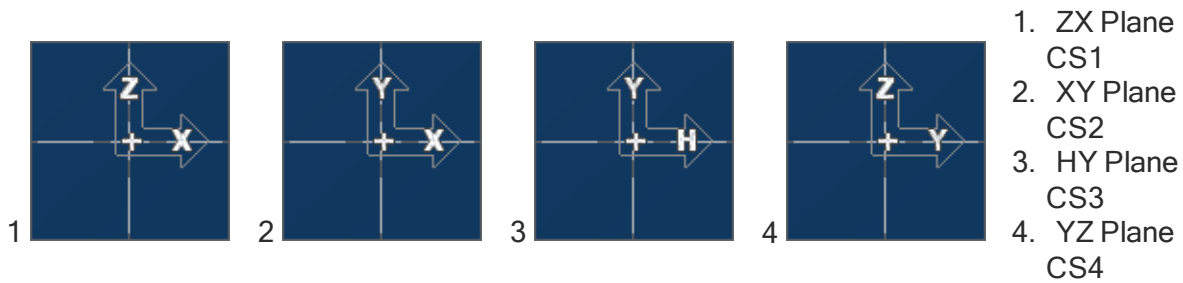

Axis markers for the four Mill/Turn planes (ZX, XY, HY and YZ).

Graphics Preference

The Graphics Preference which is accessed from the File>Preferences>Display option, contains an item called Grid Brightness. This affects the contrast and brightness of the CS grid drawn on the screen. The brightness can be adjusted by moving the slider. Clicking on the Apply button in the Graphics Preference dialog will apply the changes.



CS List

Coordinate System button

This button will access the CS list menu and the CS list. If Advanced CS is not available this button is only active when a C Axis machine is defined.

CS List menu

Click and hold the CS button to open the CS list menu which displays the four coordinate systems contained in the Mill/Turn part file.

CS List

Depress the CS button to open the CS list. This dialog displays a list of all existing coordinate systems, highlighting the current coordinate system. It is strongly recommended that the CS list remain on the screen at all times when working with multiple coordinate systems.

Each CS has an eye icon next to it. Double-click the eye of a CS to make it visible or invisible. When open, the CS Frame Indicator for that coordinate system will be displayed on the screen. This action does not affect the current CS, which will remain highlighted in the CS list. The CS grid and Axis markers will be based on the current CS.

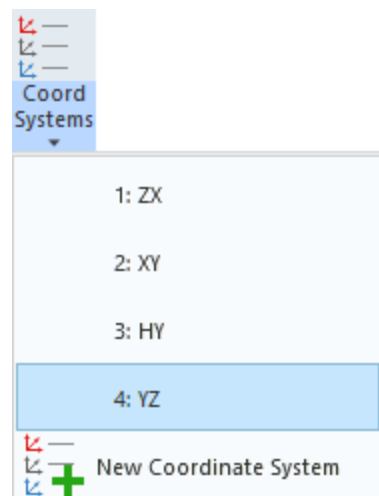

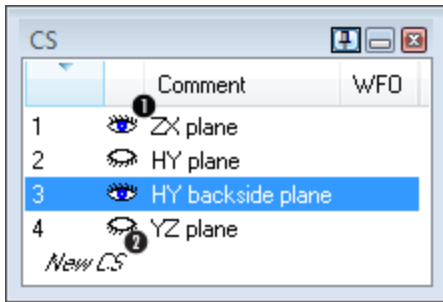

1. Visible Indicator
2. Hidden Indicator

CS Frame Indicator

The system can also display a CS frame indicator that shows the origin of another CS. CS frame Indicators are made up of three red lines that display the unlabeled three axes that make up the CS. **Click** the red lines to quickly switch from one CS to another. **Double-click** the eye icon in the CS list to show and hide a CS frame indicator. **Ctrl-click** to select/deselect multiple eye icons. **Shift-click** to select a contiguous group. Close the CS list to quickly deselect all eyes.

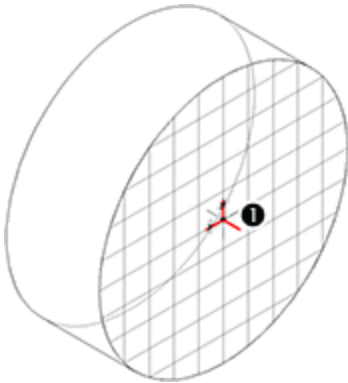

1. Indicator for XY Plane

Menu Items

The following menu items are only useful when working with multiple coordinate systems.

Edit Menu

Select Current CS:

This item is found in the Edit > Select Special submenu. When this item is selected all geometry in the current coordinate system contained in the current workgroup will become selected. Geometry and bodies in other coordinate systems or workgroups will not be selected.

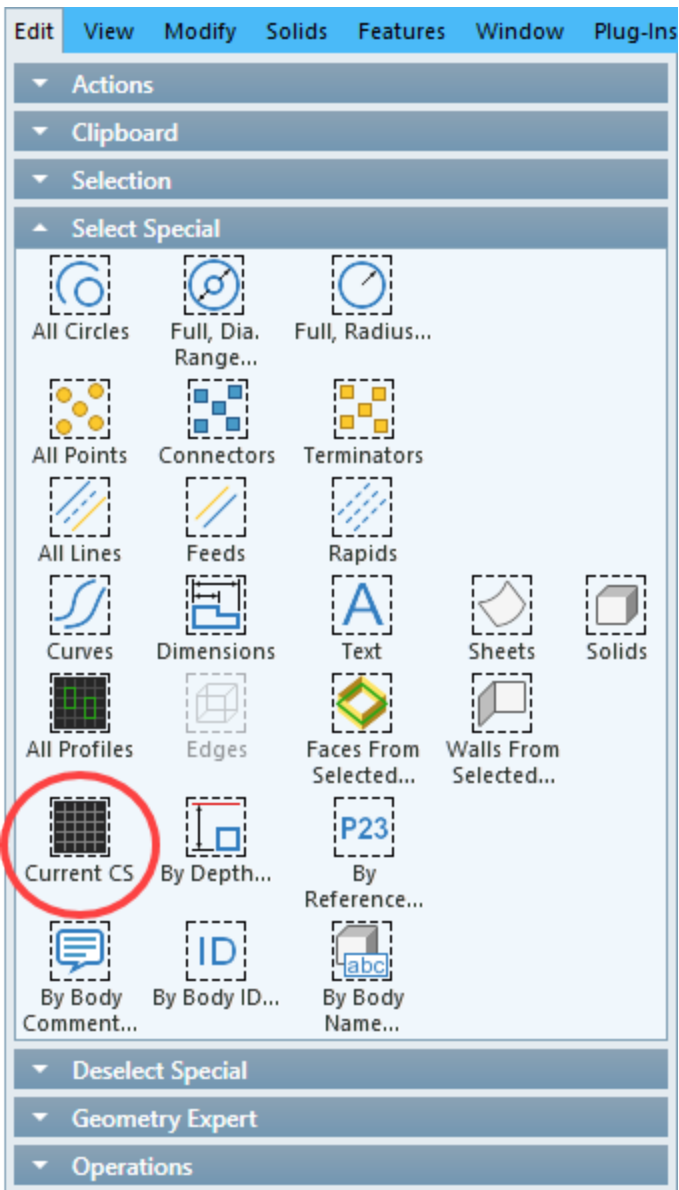

View Menu

Home view:

This item is also available as a button on the View palette. When selected, the system rotates the view of the part to a view normal (3D perpendicular) to the current coordinate system. The Home view always displays the part with the positive Depth Axis projecting out of the screen. This has the effect of showing the part rotated into the position it will be in when it is machined.

Modify Menu

The **Change CS (XYZ)** and **Change CS (HVD)** items are only available if geometry is selected. Either item will reassign geometry to the current CS.

Change CS (XYZ)

When **Change CS (XYZ)** is used, all selected geometry will be assigned to the current coordinate system. The geometry will stay in its same location in 3D space. It will change color to reflect the fact that it is now in the current coordinate system. All selected arcs will be segmented (changed into line segments), if the coordinate system they are being changed into uses a different plane than their original coordinate system.

Change CS (HVD)

When **Change CS (HVD)** is used, all selected geometry will be assigned to the current coordinate system, and the HVD values of the geometry will be preserved. This means that the geometry will be modified to be planar to the new CS location preserving the relative position.

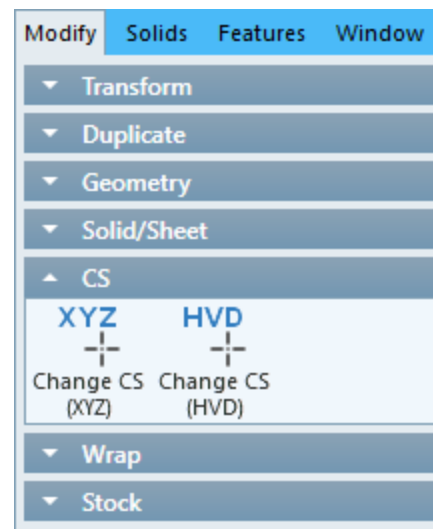

Terminology

Live Tool

When a live tool is used, the Turning spindle stops rotating and engages C Axis rotary motion. A milling tool is set to spin at a specified RPM.

Wrapped Geometry

A standard term for geometry that is drawn flat and wrapped or rotated around.



The terms coordinate system, plane, and CS are used interchangeably throughout this guide.

Comparison Summary

Mill/Turn allows you to use a live mill tool with simple angle positions of the C-axis on the OD or face of the part. Polar & Cylindrical Milling allows you to wrap geometry about the C-axis and allows continuous C-axis rotation when programming milling operations. If the machine has Y-axis capabilities any mill operation may be performed at any C-axis position.

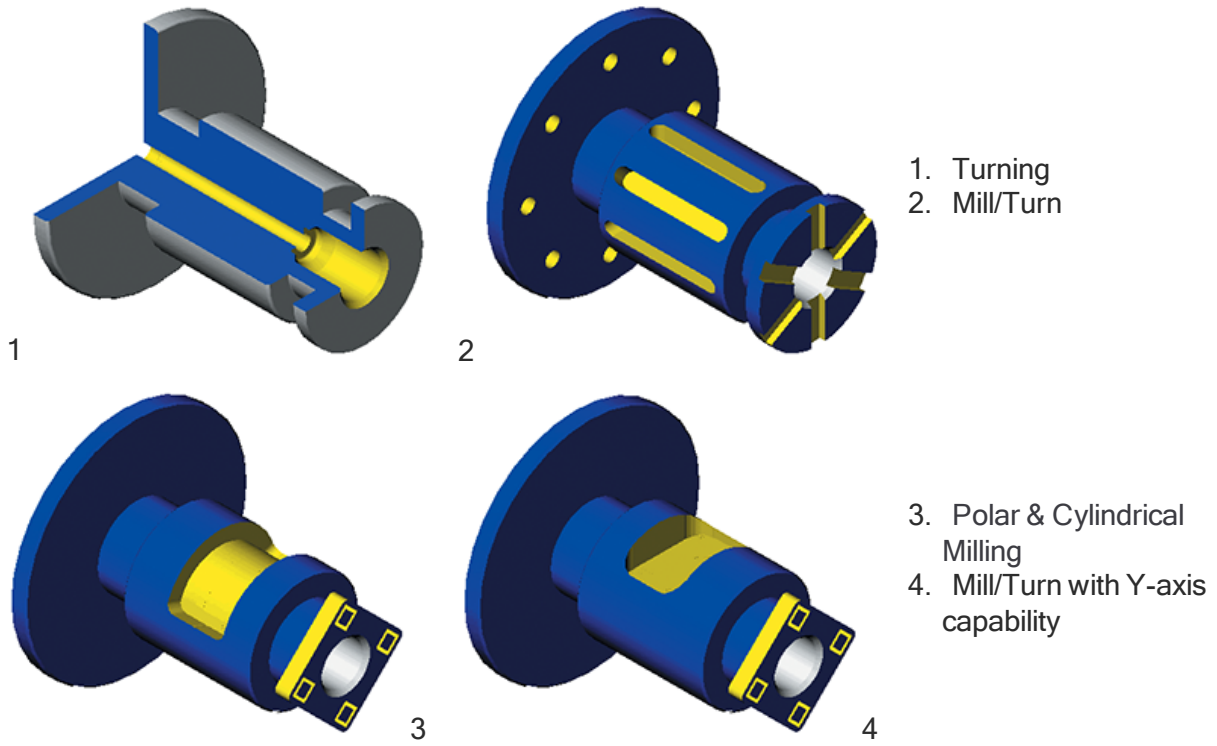

A comparison of capabilities in system modules.

Part Setup

- [Machine Definition Documents on page 13](#)
- [Mill/Turn Coordinate Systems on page 13](#)
- [Geometry Creation on page 16](#)
- [Tool Orientation on page 17](#)

Machine Definition Documents

Setting up a C Axis part is very similar to that of a standard turning part. The stock is designated in the same manner and the options for designating clearance planes are identical to that for turning parts.

Radius/Diameter

The X dimensions style (radius/diameter) selection only applies to geometry and clearance values in the ZX plane. The dimensions are designated Xr or Xd depending on the choice made in the stock setup. Turning operations can only be created in the ZX plane. Milling and other CS planes will always use the diameter Xr style.

Mill/Turn Coordinate Systems

C-Axis Turning parts create four standard coordinate systems automatically. These assist in creating geometry and machining operations on different areas of the part. The standard turning ZX plane is used for turning operations. The XY plane is used for face machining. The HY backside plane is used for machining the back face. The YZ plane is used for OD milling operations. These four coordinate systems cannot be modified.

Advanced CS allows you to create and modify user coordinate systems into any planar orientation and program positioning moves for milling operations. For Mill/Turn, the Advanced CS option allows additional coordinate systems in any orientation and create milling operations that use the non-standard coordinate systems for the machining CS.



Operations and Coordinate Systems

Turning Operations

In a turning operation, the designation of the machining coordinate system is set by the selection made in the process dialog for OD, ID or front face. The approach type selection designates the axis along which the tool will approach and cut the part. The standard turning CS is CS1: ZX plane. Turning operations also require the tool orientation to be specified, but this does not determine the machining CS. It is very important to designate the appropriate orientation in order to achieve the correct toolpath.

Milling Operations

For milling operations, the proper CS must be set by the user through the process dialog.

The machining CS is used to determine how the tool will approach the part. In milling operations the tool orientation typically designates the axis of tool approach.

Approach Types and CS Use in Mill/Turn

The following pages illustrate the proper use of Coordinate Systems within a standard Mill/Turn part.

Standard Turning CS

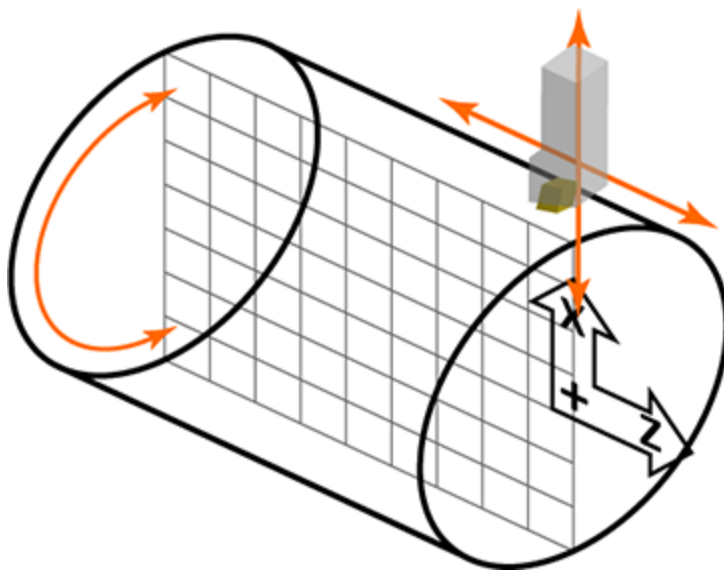

Standard OD Milling CS

Milling can include Y and C Axis moves.

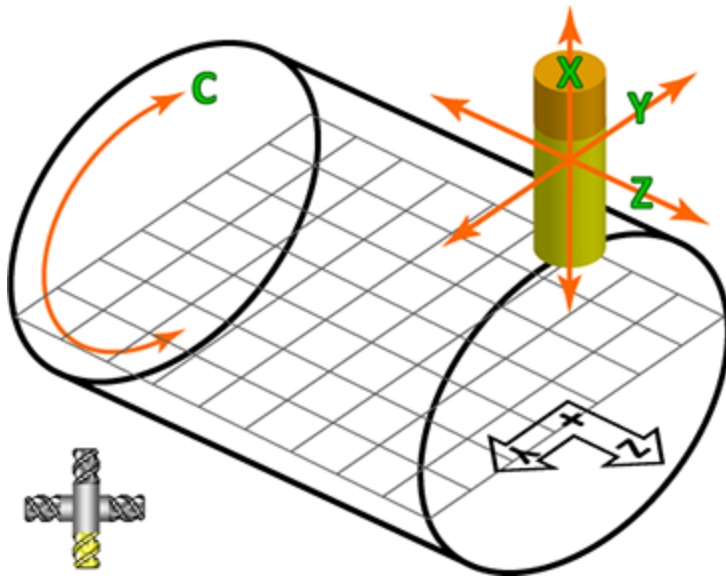

Standard Front Face Milling CS

This CS would require a front face tool orientation as shown.

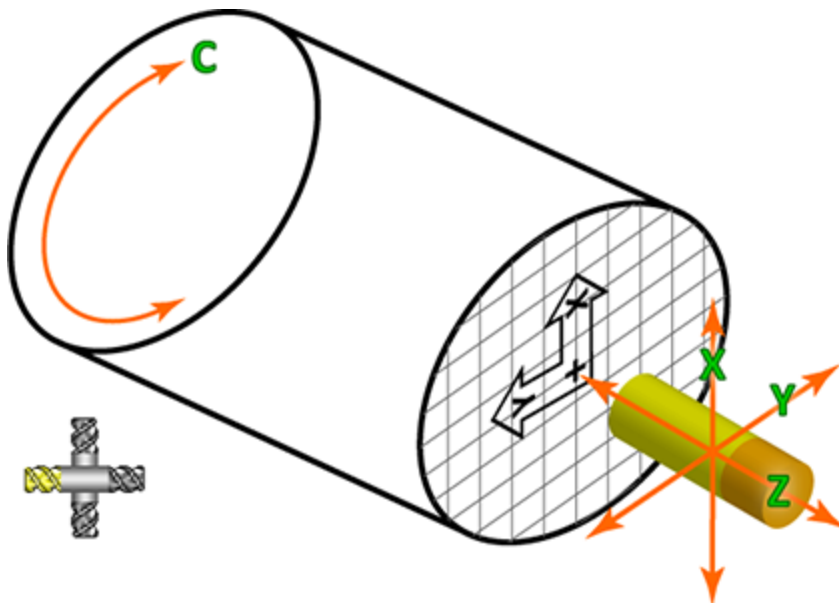

Standard Back Face Milling CS

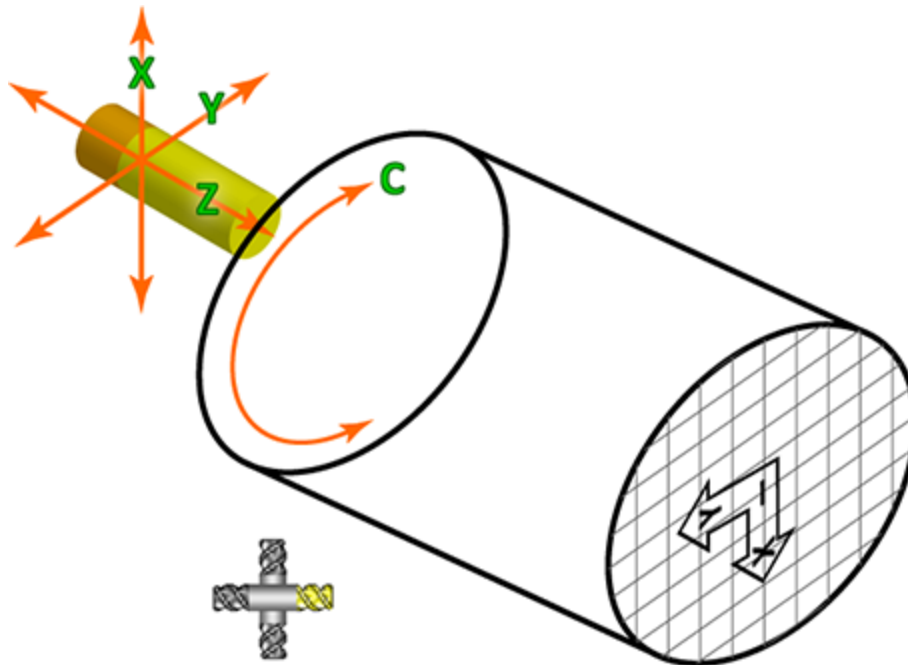

Note the vertical and Horizontal Axis markers at the origin compared to the Front Face CS in the previous image. In this view of the front face XY plane, which represents the front face has a “+” sign at the intersection of the markers indicating that the positive direction of the depth Axis is projecting outward. Switching to the Back face plane (labeled as HY) has a “-” sign on the Axis markers, indicating that the view is from the -D Axis. The +D Axis projects out from the backside of the part. Essentially the difference between the XY plane and the HY backside plane involves the depth axis along which the tool will approach the part.



When machining either the front face or the back face, the tool must approach the part from the positive Z axis of the CS. This is the reason that two coordinate systems are created to facilitate face machining.

Geometry Creation

Geometry CS contrasted to Machining CS. Geometry can be created in any coordinate system. The CS to which the geometry is assigned has no bearing on the machining CS. Typically, the machining CS is designated by the CS selected in the process dialog. If geometry is not created in the appropriate CS for the type of operation that is being created, it is very likely that the resulting toolpath will not produce the desired results. The toolpath will be created based on the machining CS, regardless of the CS of the geometry. Geometry will be machined as it is viewed from the machining CS.

Which CS for geometry? Geometry should be created in the appropriate coordinate system for the type of machining operation to be created. Geometry that defines the cut shape for OD machining

operations should be created in the YZ plane. Likewise, geometry for front face operations should be created in the XY plane and geometry for back face operations should be created in the HY backside plane. When creating geometry to be machined on the back face, it may be helpful to force the depth of the geometry so that when viewed on the screen, it appears in the correct location. This is recommended for visualization purposes only, as the machining operation and depths of cut will be calculated from the information entered in the machining process dialogs, not the location of the selected geometry.

All geometry for OD milling operations must be created in the YZ plane. Geometry is created in a position as if it were to be machined in the C0 position. The rotation is accomplished when the toolpath is created by entering an angle value in the machining process dialog. The position C0 is along the positive direction of the X axis in the standard YZ plane. The system allows the user to designate a start angle when positioning the C axis. All geometry for OD operations must be created in the standard YZ plane, regardless of the start angle. As a result, often times geometry will not be created in the exact planar location in which it will be machined. For example, if a flat slot is created on the OD to be machined at a start angle C90, the geometry would be created at C0 and when the toolpath is created it will be rotated into position.

Wrapping. Geometry can also be created and viewed radially or wrapped when the Polar & Cylindrical Milling option is installed. For more information, see the extensive discussion in [“Mill/Turn with Polar & Cylindrical Milling”](#) on page 23.

Tool Orientation

The orientation of a mill tool is a very important aspect in properly setting up a tool. By default, all tools are oriented to the main or primary spindle. That means that the tool orientation in the tool dialog should be set to match the tool’s actual position when looking at the spindles from the front of your machine.

Milling tools are slightly easier to set up than turning tools because there are fewer variations. There are only four positions – two each for horizontal and vertical. For machines with B-axis support, the tool may be used in a range of orientations, and this is controlled by the Machining CS setting found in Process dialogs. Please note that the orientation specified is when the B-axis is zero.

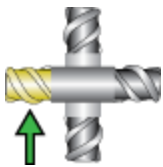

Approach towards the face of the main spindle.

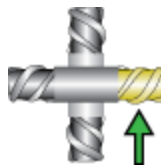

Approach away from the face of the main spindle or back side milling.

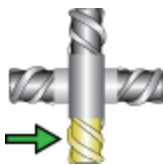

Approach from the +X side.

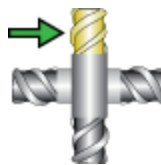

Approach from the -X side.

Tool Orientation Diagram

Setting the proper tool orientation is very important as it determines the axis along which the tool will approach and machine the part. There are two basic axes along which the tool will travel, the X axis, for OD operations, and the Z axis for face operations. To select the tool orientation, click one of the four positions on the diagram so that it becomes highlighted.

If the tool orientation is not set correctly, the toolpath that will be generated will not produce the desired results. Often times, the system will not be able to create a toolpath if the tool orientation is not set correctly. Always check the tool orientation diagram if the toolpath (or lack thereof) does not seem correct.

The image labels the tool orientation diagram according to the approach axis of the selection and also what section of the part should be cut given the selection. It should be noted that a tool approaching along the X axis, while typically used for OD work can also be applied to milling operations cutting the face.

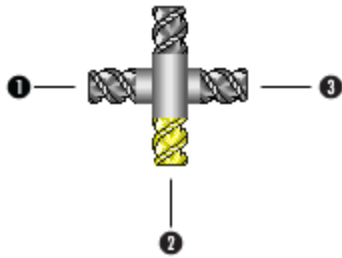

1. Z Axis Approach (Front Face)
2. X-axis Approach (OD)
3. Z-axis Approach (Back Face)



TOOL SETUP DATA

The Tool creation dialog contains a Tool Setup button. This allows you to add Toolblocks created within Intermediate Tooling, to a Tool and its Toolholder. The Toolblock and the Toolholder can be fully visualized to double-check orientation.

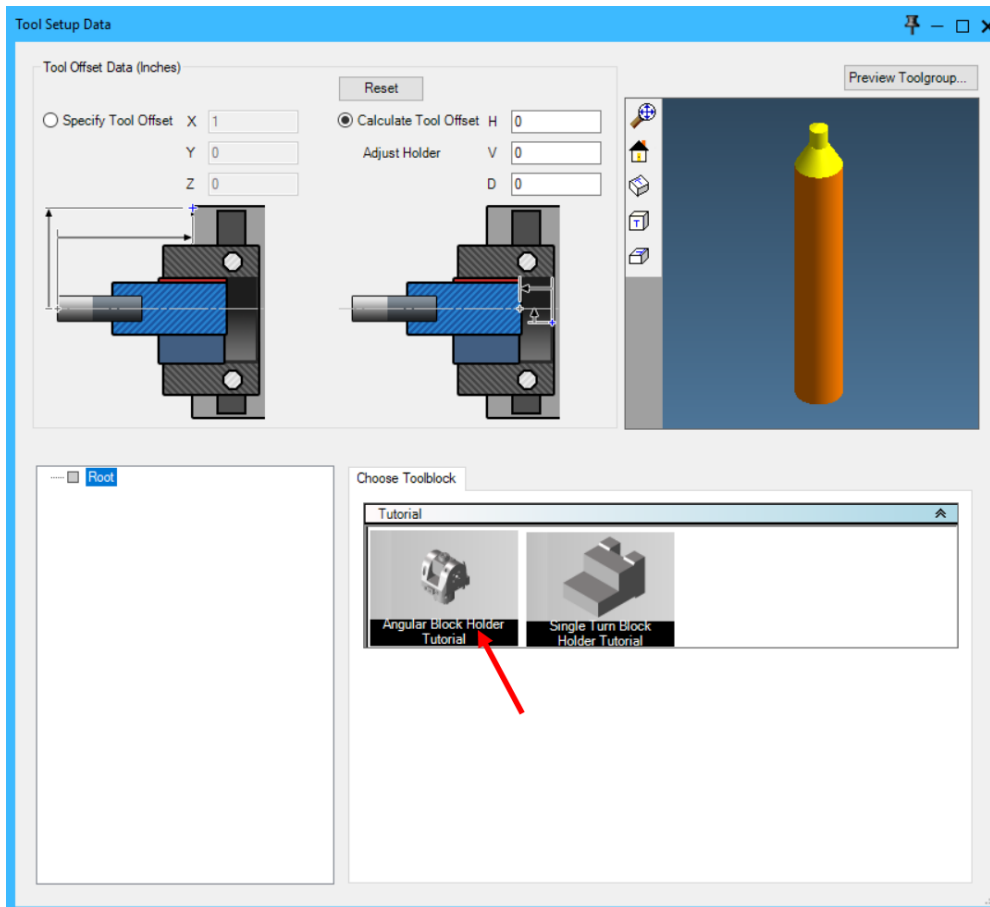

Machining

- “Processes ” on page 20
- “Y Axis Interpolation and C Axis Interpolation” on page 21

Processes

When one of the Mill/Turn MDDs is selected, the machining palette can be used to create milling and turning operations. The processes have the same functionality as standard mill and turning parts. For detailed information on the processes, refer to the Mill and Turning manuals.

Milling Rotate Tab

When the MDD has a rotating axis, milling Process dialogs have a Rotate tab. The Rotate tab lets you designate C-axis rotation for the operation. The Rotate tab in milling processes contains two selections for rotating the part: Position and Polar & Cylindrical Milling. The Polar & Cylindrical Milling selection is available only if the Polar & Cylindrical Milling option is purchased.

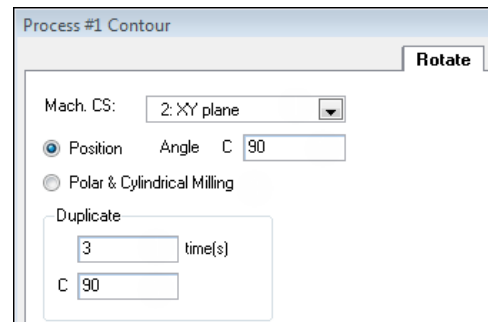

Position

Position lets you enter an angle of rotation for the C Axis, which designates the position in which the toolpath will be created. When the toolpath is generated, the system will display it in the proper location based on the angle value entered. It is independent of the geometry selected. Geometry created for face operations should be based on the XY plane and geometry for OD operations should be created in the YZ plane. All geometry for OD operations is created in the YZ plane in the C0 position. The position rotation is accomplished when the toolpath is created. The posted code will contain the appropriate C Axis positioning moves.

Duplicate allows for subroutine repeats at equal angular intervals of the toolpath generated by the operation. The system will create the toolpath dictated by the Position information and duplicate that toolpath a specified number of times at the interval angle position entered in the C text box. The value entered in the times text box is the additional number of times the toolpath will be repeated. For example, if you are creating a toolpath using Position at a specified C angle, the process will create the toolpath at that angle and then duplicate it the given number of times at the given angle intervals. Thus the Duplicate # is the total number of subroutines the operation is to be performed minus one for the original step.

The C rotations position corresponds to the positive direction of the X Axis and proceed in a clockwise direction. Negative values are valid for start angle positions. For example, a value of -45 could be used, which is identical to entering 315. The value entered for the start position should be in angle measured in degrees.

Y Axis Interpolation and C Axis Interpolation

The Y axis allows movement which is perpendicular to the rotation of the part. For instance, a Face Milling process without a Y axis would require the part to rotate to cut a flat surfaces. This is called C-axis interpolation. The rotation of the C axis will be used to achieve any movements needed in Y. To achieve this, be sure to select Polar & Cylindrical Milling in the Process dialog.

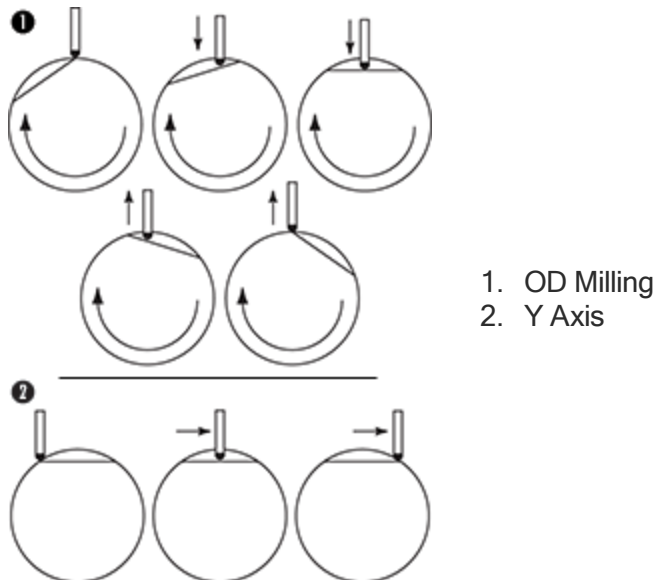

A Y-axis toolpath cannot be wrapped. If Position is selected in the Rotate tab, only Y-axis moves are created. In other words, Y-axis moves are not generated when creating a wrapped or Polar & Cylindrical Milling toolpath. When Polar & Cylindrical Milling is being used, all movements are converted to C-axis interpolation.

The image shown to the right illustrates some of the differences in Y-axis and C-axis OD moves of the same process. The top set of images comes from a machine that does not have Y-axis capabilities,; the second set from a machine that does support Y axis.



A Y-axis-capable machine can produce this same movement as the C-axis interpolation by selecting Polar & Cylindrical Milling in the Rotate tab.

The image below illustrates a face milling contour would use interpolation with C-axis and Y-axis moves. The last image in each set shows the tool as an overlay to demonstrate all movement.

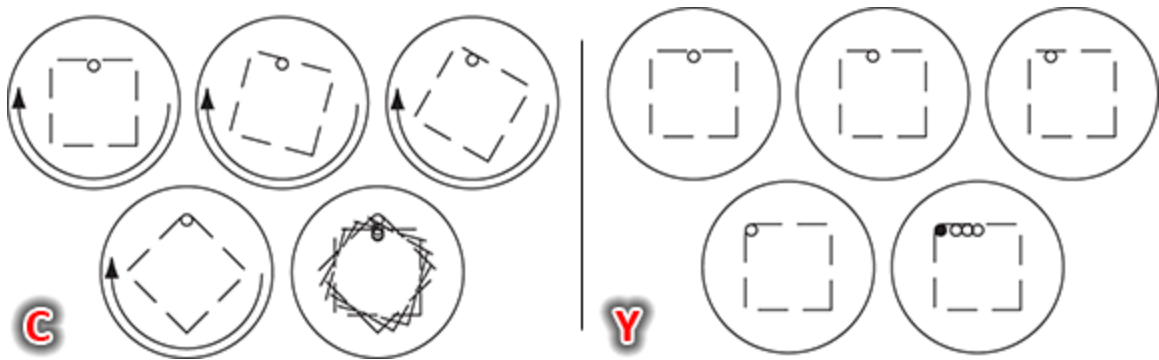

A face milling contour with C-axis and Y-axis moves

Mill/Turn with Polar & Cylindrical Milling

If Polar & Cylindrical Milling is available, it allows C-axis rotation in milling operations. This is often referred to as *wrapping*. This section describes functions that are specific to Mill/Turn when the Polar & Cylindrical Milling option is installed. This section assumes a familiarity with the standard Polar & Cylindrical Milling functionality described in the [Mill](#) guide.

C Axis Interpolation for Polar and Cylindrical Milling

The Polar & Cylindrical Milling option enables wrapped geometry and toolpath about the C axis by rotary interpolation of the C axis in milling operations.

Rotate Tab

The **Rotate** tab for rotary milling processes contains two rotation options: **Position**, and **Polar & Cylindrical Milling**. The operation can either be programmed as a simple position move (**Position**) or as a wrapped toolpath which will have continuous C Axis motion (**Polar & Cylindrical Milling**). The **Position** option is described in “[Milling Rotate Tab](#)” on page 20.

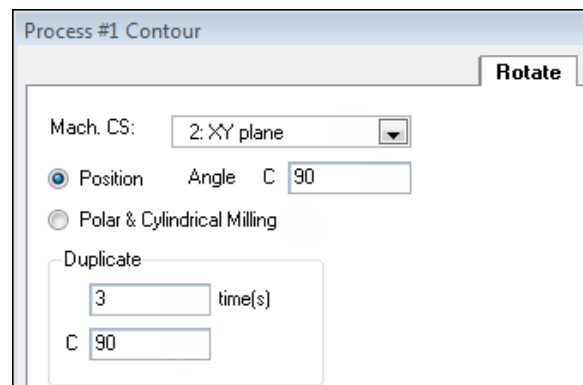

Radial Geometry

Mill/Turn wrapped geometry is designated above the standard **YZ** plane CS using a C-axis value for the angle of rotation. Geometry does not need to be wrapped in order to be machined using the Polar & Cylindrical Milling function. The toolpath that results with the Polar & Cylindrical Milling option checked will be the same whether the geometry selected for the cut shape is flat or wrapped.

Defining a Rotary WG

To put a Workgroup into *radial mode*, two interface items must be selected. First: In the Workgroup Info dialog, the **Wrapped** checkbox must be selected. Second: In the floating toolbar, the **Wrap**

WGs button  must be selected.

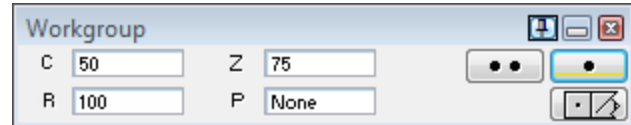
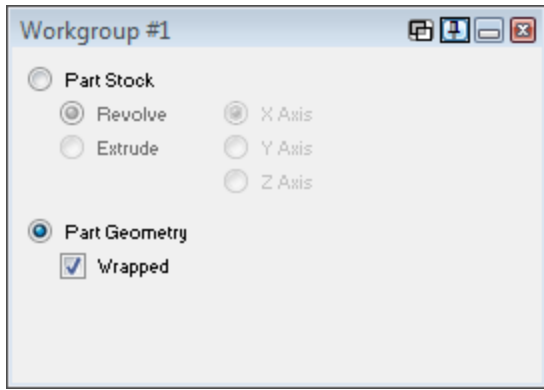

When you work in radial mode, geometry dialogs that require coordinate input will contain specifications for a C value, which is the angle of rotation and a radius value. For example, with point creation using coordinates, the dialog will not be labeled with Y, Z, and Xr, but rather C, Z, and R.

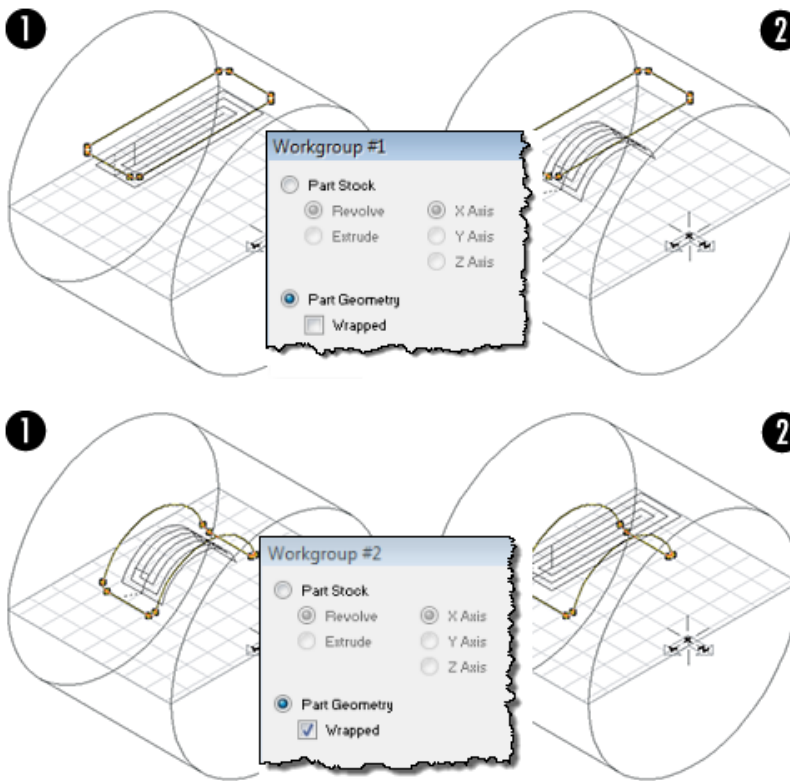

1. Designated as "Position" in the process dialog.
2. Designated as "Polar & Cylindrical Milling" in the process dialog.

Geometry and toolpath variations with Wrap Geometry button active

Conventions

GibbsCAM documentation uses two special fonts to represent screen text and **keystrokes or mouse actions**. Other conventions in text and graphics are used to allow quick skimming, to suppress irrelevancy, or to indicate links.

Text

Screen text. Text with this appearance indicates text that appears in GibbsCAM or on your monitor. Typically this is a button or text for a dialog.

Keystroke/Mouse. Text with this appearance indicates a keystroke or mouse action, such as **Ctrl+C** or **right-click**.

Code. Text with this appearance indicates computer code, such as lines in a macro or a block of G-code.

Graphics

Some graphics are altered so as to de-emphasize irrelevant information. A “torn” edge signifies an intentional omission. Portions of a graphic might be blurred or dimmed to highlight the item being discussed. For example:

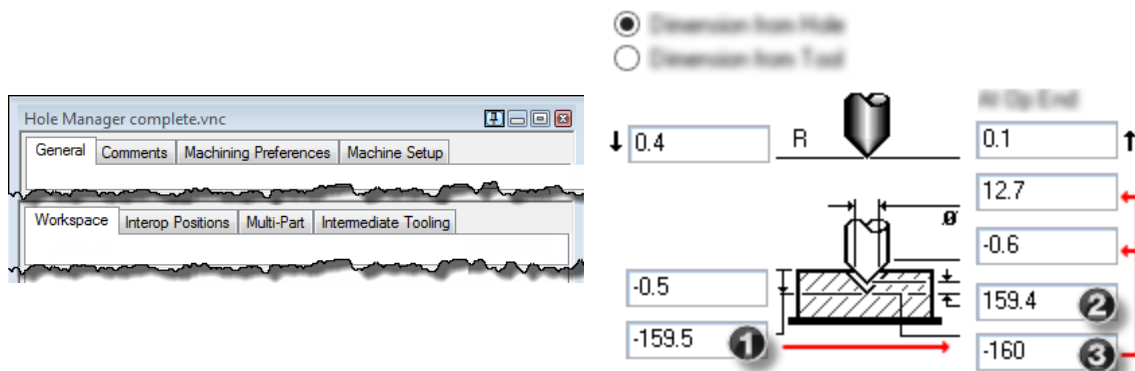

Annotations on a graphic are usually numbered callouts (as seen above), and sometimes include green circles, arrows, or tie-lines to focus attention on a particular portion of the graphic.

Faint green borders that outline areas within a graphic usually signify an image map. In online help or a PDF viewer, you can click a green-bordered area to follow the link.

Links to Online Resources

Link	URL	Action / Description
Go	http://www.GibbsCAM.com	Opens the main website for GibbsCAM.
Go	https://online.gibbscam.com	Opens a restricted website containing materials available for download. Requires a GibbsCAM Online Services account; to set up an account, contact GibbsCAM Support.
Go	https://store.GibbsCAM.com	Opens the website for the GibbsCAM Student Store.
Go	https://macros.gibbscam.com	Opens a wiki containing documentation and examples of GibbsCAM macros. Requires a GibbsCAM account.
Go	http://kb01.GibbsCAM.com	Opens a Knowledge Base article, Contour Operations Using Thread Mill Tools , that explains in detail the correct way to program Contour processes using Thread Mill tools.
Go	mailto:Support@gibbscam.com	Runs your email client to create a new message addressed to the CAMBRIO Technical Support department for GibbsCAM.
Go	mailto:Registration@gibbscam.com	Runs your email client to create a new message addressed to the CAMBRIO Registration department for GibbsCAM.
Go	mailto:Sales@gibbscam.com	Runs your email client to create a new message addressed to the CAMBRIO Sales department for GibbsCAM.
Go	http://www.autodesk.com/inventor	Opens an external website that provides more information on Autodesk Inventor products.
Go	http://www.celeritive.com	Opens an external website that provides more information on VoluMill Ultra High-Performance Toolpath (UHPT) from Celeritive Technologies.
Go	http://www.predator-software.com	Opens an external website that provides more information on a CNC editor and a virtual CNC viewer from Predator Software, Inc.